

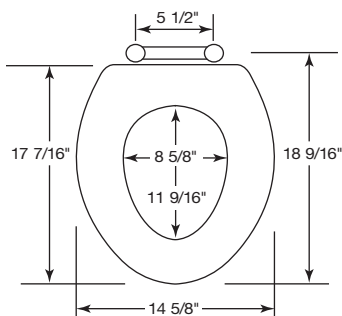

RESIDENTIAL MOLDED WOOD SEATS

MODEL 1960PCH

- ELONGATED SEAT, CLOSED FRONT WITH COVER
- MOLDED WOOD
- BAR HINGE, CHROME OR WHITE HINGE CAPS



Seats shall be 1960PCH as manufactured by Church Seats. Seats shall be heavy-duty molded wood, multi-coat enamel finish with closed front and cover to fit elongated bowl. Color matched bumpers and hinges. Available with hinge caps in either chrome or white to match bath hardware. Hinge shall be bar type. Color to be white.

Ring thickness is 13/16"
Ring thickness including the bumper is 1-1/8"
Height of the seat with cover is 2-1/2"



CHROME OR WHITE HINGE CAPS